

54TH JPM IN-STORE MARKETING SHOW & AWARDS 2025

ENTRY GUIDELINES FOR POP ADS & IN-STORE ADS WORKS

JPM In-store Marketing Show & Awards

Officially licensed by  **Enhancing Retail**
Environments & Experiences

The "JPM In-Store Marketing Show & Awards" organized by JPM is the only POP ads & In-Store ads contest in Japan and one of the largest in the world. It is held annually with the aim of awarding POP advertisements, promotional spaces, and POP packages that make consumers' purchasing behavior a richer experience and raising public awareness of promotional marketing. This is a global standard award officially licensed for the Shop! OMA Awards program from the Shop! Association.

promotional marketing : marketing on all areas to promote consumers' purchasing behavior

About Shop!

Shop! Association (Shop!) shopassociation.org

The global trade association dedicated to enhancing retail environments and experiences. Shop! focuses on supporting an environment in which all individuals feel respected and are treated fairly, and different viewpoints, opinions, thoughts and ideas are encouraged and embraced. .

Shop! OMA Awards program

OMA stands for Outstanding Merchandising Achievement. The Shop! OMA Awards are world-class awards that have recognized the most innovative and effective in-store and POP displays for over 60 years. JPM has been licensed for the Shop! OMA Awards program since 2019. This will allow JPM In-Store Marketing Show & Awards Gold award-winning works to enter the Shop! Global Awards, alongside Gold award-winning works from the Shop! OMA Awards and Shop! affiliates own industry awards around the world.



The Shop! OMA Trophy is a modern, global image design that reflects Shop! Association's brand identity and a symbol of the industry's highest honor in common throughout the world.

POP (point-of-purchase) and in-store advertising defined by JPM

The role required of POP and in-store advertising is also changing significantly in order to respond to the changing purchasing behavior of consumers due to the development and spread of digital technology. As well as POP (point-of-purchase advertising) as a final purchase promotion in the conventional physical store, store designs and displays for attracting customers to the store, tools that indirectly lead to purchasing promotion by functioning in the "search" and "sharing/spreading" phases, which are becoming more important due to the spread of SNS, as well as promotional spaces such as pop-up stores for a limited period of time, all of them are conceptually defined as in-store advertising.

* Tools and signs that do not indirectly lead to purchases (for example, window displays that produce only a sense of the season) are not POP or in-store marketing advertising.

* Digital content alone to promote "search" and "sharing/spreading" is not POP or in-store advertising.

ENTRY REQUIREMENTS

Requirements

1. Entries are limited to JPM members, but overseas companies are welcome even if they are not members of JPM.
2. Works actually used between September 1, 2024 and August 31, 2025 are eligible.
3. Entries must be made by category; See pages 6, 7 and 8 for details.
4. Works with a minimum run of 10 or more are accepted. However, for the "Promotion/Space Design" category and "Minimum Lot" category (newly established), see page 7.
5. As a general rule, all entries are for individual items (1 piece), except for the "Large Kits" and "Small Kits" categories. However, the following works will be considered as individual items.
 - Unit displays with a minimum quantity to perform their functions.
 - For small works that are the same and intended for multiple exhibits at the time of planning, or those that have the same shape but different colors and different displays, about 3 pieces can be entered and exhibited within a footprint of 300 mm wide x 300 mm deep.
 - Small works displayed in the showcase can be entered if an example of deployment or an instruction manual is attached.

More details will be provided after the first judging, so please follow the instructions.

6. Works that pass the first judging will be exhibited at the JPM In-Store Marketing Show & Awards (an exhibition fee for selected works will be charged).
7. Basic exhibit unit dimensions are 990 mm wide x 990 mm deep x 2,700 mm high. When using the exhibit table, the table dimensions are 990 mm wide x 495 mm deep x 900 mm high.

The standard size for a 900 height counter is **990 wide by 495 deep**.

However, even if counter exhibits exceed the standard size, the width and depth can be expanded to accommodate them.

Considering the counter height of 900mm, please make sure that the height of exhibits on the counter does not exceed 1800mm.

Please note that panels for supplementary explanations are also included in the exhibition space.

*The panel size should be within the basic A4 size, and each exhibitor is requested to provide its own paper foot-stand, self-supporting stand, etc.

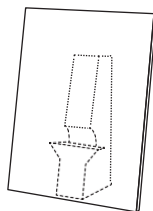

paper foot-stand

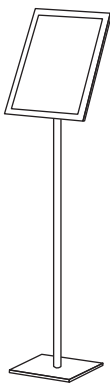

self-supporting stand

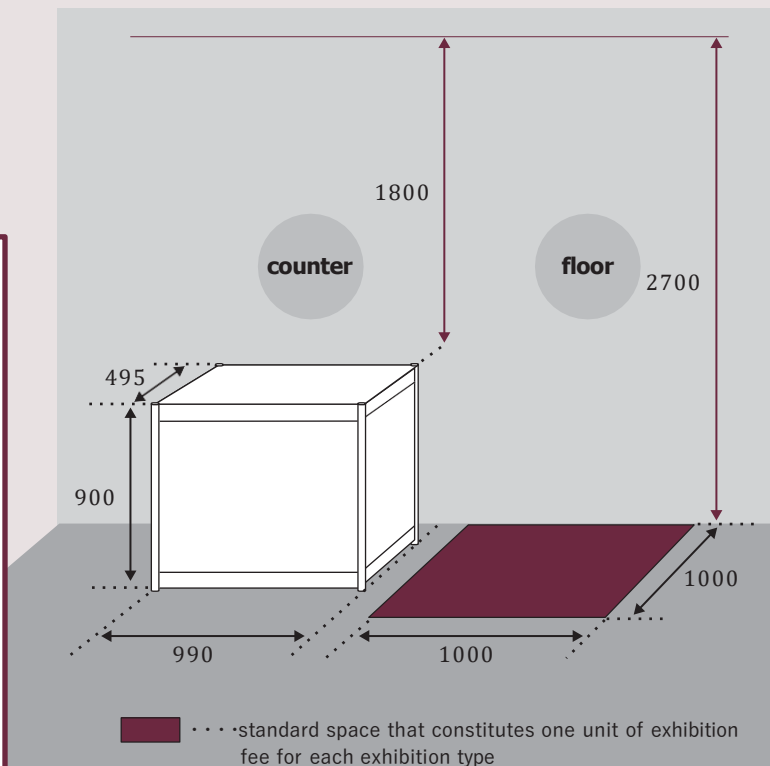

8. Additional fees will be charged for those that fall under the following. (For more details, see page 5 (2) for judging and selected exhibit fees)
 - A) Works with the footprint of 1 m or more on each side
 - B) Works in the "Large Kits" category with Large Kits surcharges
 - C) Works that exceed the exhibit unit dimensions originally entered if JPM has determined to increase the allocation of exhibit footprint in consideration of the sizes, shape, or characteristics of the works as a result of the first judging

ENTRY PROCEDURE

Procedure

- 1 Entries with photo data need to be made from the Google Forms entry page (<https://forms.gle/xwhPgLwACkhGfbWp7>). Please refer to the attached "Online Entry Basic Operation Manual" for details on the input method, etc.
- 2 Photo data needs to be in JPEG high-quality compression (RGB) format, equivalent to 1MB (350 to 400dpi, 50 mm x 60 mm) to 3MB (350 to 400dpi, A5 size). Images with a small amount of data, images created with PowerPoint, or PDF are not accepted.
- 3 The photos of the works need to be taken independently with a plain background. You may submit up to 8 images.
- 4 Please take the photos of your works by setting them up in the same way as you will exhibit at JPM In-Store Marketing Show & Awards.
- 5 Photo data will be published directly in guidebooks and other publications.
- 6 The text data entered in the "Objective for the work" of the entry form will appear directly on the exhibition work card and other materials.
- 7 We are preparing to allow you to enter your video on the entry form (details will be provided in the online manual).

Entry Acceptance Period

July 15, Tuesday, 2025 to September 4, Thursday, 2025

Setup and Removal of Exhibits

<Show place: Tokyo Metropolitan Industrial Trade Center, Hamamatsucho-kan>

December 9 (Tue): Venue setup

December 10 (Wed): Morning - Delivery and setup of exhibit works continue / Afternoon - Second, third and final judging

December 11 (Thu): 10: 00 to 19: 00 - Show open (last admission 18:30)

December 12 (Fri): 10: 00 to 17: 00 - Show open (last admission 16:30) / 17: 30 - Removal of exhibits

<Notes>

- Exhibit works must be delivered on Wednesday morning, December 10, and the removal of the exhibits is in the evening of December 12, Friday.
- Working hours for the setup and removal of the exhibits must be strictly managed following the guidelines provided by JPM.
- More details for the work exhibits will be announced in late September along with the results of the first judging.

Co-Entries

1. Co-entry of two or more companies is accepted. In this case, you need to make one company as the entry company and the other/others as the co-entry company/companies. Co-entry companies do not need to be JPM members.
2. If you do not enter the co-entry company/companies at the time of co-entry, it will not be recognized as a co-entry and you will not be able to add such co-entry company/companies after winning the award.
3. Co-entries will be billed collectively to each entry company.

Special Notes

1. For works that are found not meeting the entry requirements, the entries will be eliminated even after the judging has been completed. Further, even if any of such works happened to be an award winning work, the runner-up work will not be awarded.
2. Works with flammability notification cannot be exhibited, but the ones without the contents can be accepted.

JUDGING

Judging Structure

● First judging (Winners selection)

A panel of 11 judges from JPM will review all entries by photos and documents and select the winners.

● Second judging (Silver Award winners)

A panel of 20 judges, first 11 judges plus 9 judges from JPM will review the actual works and decide the Silver Award winner/winners for each category.

● Third judging (Gold Award winners)

The third judging committee of 9 (see below) will review all Silver Award winners and decide one Gold Award winner for each category.

● Final judging (Minister of Economy, Trade and Industry Award※ winner)

The third judging committee of 9 will decide one Minister of Economy, Trade and Industry Award winner from all the Gold Award winners.

※Application is in preparation.

● Announcement of winners

All winners will be announced on the JPM website and the JPM In-Store Marketing Show & Awards website.

Second and Third Judging Criteria

1. The concept is original.
2. Design and engineering are excellent.
3. Material selection and manufacturing costs are appropriate.
4. Sufficient consideration is given to distribution and time of use.
5. Great marketing effect.

* "Sugowaza (Great Performance)", "Promotion/Space Design" and "Minimum Lot" (newly established) categories will be judged by different criteria.

Final Judging Criteria

1. Excellent solution power at the time of purchase.
2. The concept is original.
3. The consumer interest perspective is clear.

Third and Final Judging Committee

Chief judge Toshio Yamagata (Professor Emeritus, Tama Art University)

Toshio Yamagata (Professor Emeritus, Tama Art University)

Taketoshi Terai (Professor, Kanazawa College of Art)

Ikue Morishita (Editorial Department, Senden Kaigi Co., Ltd.)

Takeya Kurabayashi (President, Retail Insight Co., Ltd.)

Fumihiro Kousaka (Director, Art and Culture Group, J.F. Oberlin University <Visual Arts>)

Satoshi Nakajima (Executive director, Japan Advertisers Association)

Akihiko Kondo (Board Director, JPM)

Naoto Hayashi (Chief of Young Design Dept, JPM)

Hideaki Kubota (JPM Adviser)

— Increase in the Exhibit Fee and Discounts for Increasing the Number of Items on Display —

We have raised the exhibition fee. Exhibitors who have exhibited more items than last year will receive a 10% discount for the increased number of items.

The unit price differs for each work, such as kit, space, and joint exhibits, etc. The average unit price is calculated from the total amount for each exhibitor, and the amount of discount is calculated using the following formula (increased number of items x average unit price x 0.9).

Judging Fee (Invoice will be sent after the first judging)

JPY8,000 per entry / JPY5,000 per company for co-entry

JPY18,000 per entry for non-members from overseas

Selected Exhibit Fee (Invoice will be sent after the first judging)

- 1 JPY21,300 per exhibit / JPY16,500 per exhibit & per company for co-entry
JPY50,000 per exhibit for non-members from overseas
- 2 Surcharges for the space and "Large Kits" category (Page 2 ENTRY REQUIREMENTS: For works that meet the requirement (7), the following surcharges A or B will be added to each selected exhibit fee of (1)21,300 yen).

A) Space surcharges (All categories except "Large Kits"): JPY6,600 per side for 1m or more, JPY13,200 per side for 2 m or more, JPY21,300 per side for 3 m or more

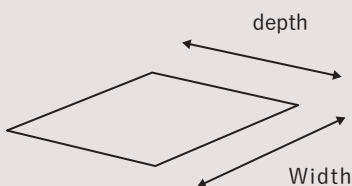

Width or depth is 1 m or more: JPY6,600 per side
 Width or depth is 2 m or more: JPY13,200 per side
 Width or depth is 3 m or more: JPY21,300 per side increase

<Example> If the exhibit dimensions are 2,500 mm wide x 1,500 mm deep x 1,500 mm high, JPY13,200 for width 2 m or more and JPY6,600 for depth 1 m or more, in total JPY19,800 will be added.

B) "Large Kits" surcharges: JPY21,300 per exhibit will be added for each additional exhibit unit (990 mm wide x 990 mm deep x 2,700 mm high or less). You can request for up to 6 units as needed.

EXHIBIT UNIT DIMENSIONS

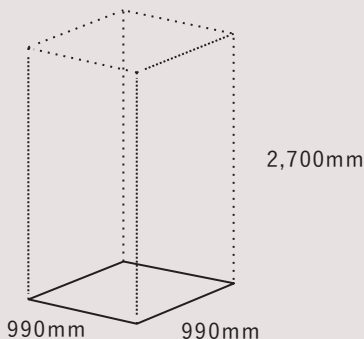

EXHIBIT UNIT DIMENSIONS

990 mm x 990 mm x 2,700 mm: JPY21,300 per unit

<Example> If the exhibit dimensions are 3,600 mm wide x 990 mm deep x 2,700 mm high, it calculates $3,600 \text{ mm} \div 990 \text{ mm} = 3.6 \approx 4$ (*), for a total of $\text{JPY}21,300 \times 4 \text{ units} = \text{JPY}85,200$ will be added. (* The fraction will be rounded up)

ENTRY CATEGORY CLASSIFICATION

- (1) For entries, please read the following notes and enter each appropriate code number from the "ENTRY CATEGORY CLASSIFICATION and CODE TABLE" on page 8.
 - ① "Pharmaceuticals/Medical Supplies": Includes medicines, thermometers, pesticides, energy drinks, medical contact lenses and masks
 - ② "Toiletries": Includes dental products, soaps, detergents, bath salts, hair coloring and hair care products, hair restorers, hand creams, and fresheners
"Cosmetics" (common from ③ to ⑨): Includes perfumes, eau de colognes, lip balms, facial soaps, cleansers and enamel colors
 - ③ "Cosmetics counter type - Sales & Display A": Unit price less than JPY1,500
 - ④ "Cosmetics counter type - Sales & Display B": Unit price JPY1,500 to less than JPY3,000
 - ⑤ "Cosmetics counter type - Sales & Display C": Unit price JPY3,000 or more
 - ⑥ "Cosmetics counter type - Announcement & Presentation A": Unit price less than JPY5,000
 - ⑦ "Cosmetics counter type - Announcement & Presentation B": Unit price JPY5,000 or more
 - ⑧ "Cosmetics floor type A": Unit price less than JPY10,000
 - ⑨ "Cosmetics floor type B": Unit price JPY10,000 or more
 - ⑩ "Audio/AV Equipment/Communication/Office Equipment/Cameras": Includes TVs, radios, VCRs, recording & storage media, video cameras, digital cameras, smart phones, personal computers, personal computer peripherals, telephones, and faxes
 - ⑪ "Stationery/Fashion Accessories/Glasses/Watches": Includes color contacts
 - ⑫ "Household Goods/Home Appliances counter type": Includes household miscellaneous goods, thermos, washing machines, refrigerators, air conditioners, electric fans, hair dryers and sphygmomanometer, etc.
 - ⑬ "Household Goods/Home Appliances floor type": Includes household miscellaneous goods, thermos, washing machines, refrigerators, air conditioners, electric fans, hair dryers and sphygmomanometer, etc.
 - ⑭ "Food, beverages, alcoholic beverages": Includes confectionery, seasonings, supplements, beer, non-alcoholic beer, whiskey, wine, etc.
 - ⑮ "Transportation/Energy/Sports/Travel": Includes automobiles, car accessories, bicycles, transportation, gas, electricity, and sports equipment
 - ⑯ "Publishing/Entertainment/Finance/Tobacco/Other industries": Includes clothing, pet-related, DIY, housing, distribution (retail) business, game consoles, toys, electronic cigarettes and tobacco-related products, etc.
 - ⑰ "Hangers A": Unit price less than JPY1,000 and includes ceiling
 - ⑱ "Hangers B": Unit price JPY1,000 or more and Includes ceiling
 - ⑲ "Show Cards/Stickers": Includes small items such as bottle toppers and flapping
 - ⑳ "Shop Curtains/Banners/Flags/Tapestries/Walls": Including hanging curtains, large banners
 - ㉑ "Streamers/Standing Signboards/Inflatable/Cutouts": Floor type only
 - ㉒ "Signs": Small items such as signboards in storefronts and stores
 - ㉓ "Small Kits": Refers to less than one gondola fixture (up to 1 to 2 shelves) such as partial use of gondola, standard partial kit, counter kit
 - ㉔ "Large Kits": Refers to one gondola fixture or more such as end displays and islands
 - ㉕ "POP Packages": Applies to packages with sales promotion functions, having a POP feature with some ingenuity

- ②⑥ "Sugowaza" (Great Performance): This category appeals to the originality and ingenuity in terms of engineering. We welcome works that meet any of the following:
- Design, materials, structure, processing, functions, etc. are innovative.
 - Above combination breaks the conventional wisdom.
 - Special consideration is given to distribution (transportation/stores) and the environment.
- ②⑦ "Global": Applies to works used in overseas markets regardless of the nationality of the advertiser or entry company.
- * Not eligible for Minister of Economy, Trade and Industry Award.
- ②⑧ "Promotion/Space Design": Please submit entries that meet the following criteria.
- Not a permanent facility, but selling products on the spot for a limited time (or adjacent to the sales floor).
 - Pop-up stores are accepted, but exhibition showrooms are not.
 - Work that run only one are accepted as long as the execution example is clear.
 - Exhibit at JPM Show will be displayed on a B1 panel. Panel must be 728mm x 1,030mm in size, vertical position, using a poster frame. Please contact JPM for the contents of the panel.
- *Not eligible for Minister of Economy, Trade and Industry Award.
- ②⑨ "Minimum Lot": Please submit entries that meet the following criteria.
- POP ads for 1 to 9 manufactured items.
- POP ads targeting only one store, which were previously unavailable, can be submitted.
- Works of any shape, large or small, are welcome. You can apply for everything from countertop type to large displays.
 - Works that do not require construction are eligible. Works requiring construction should be submitted in the "Promotion/Space Design" category.
 - In principle, actual works are to be displayed at the JPM Show, but if you cannot bring your own, B1panels are acceptable.
- *Not eligible for Minister of Economy, Trade and Industry Award.
- (2) The classification policies are as follows:
- The categories ① to ⑩ are classified by industry into "counter type" and "floor type", and are further classified by unit price except for ⑫ and ⑬.
 - The categories ⑭ to ⑳ are classified by form, and ⑰ and ⑱ are further classified by unit price.
 - The categories ㉔, ㉕ and ㉖ are "Others". ㉗ and ㉘ are "Special".
 - Entries in the categories ⑰, ⑱, ㉓, ㉔, ㉕, ㉖ can also enter into the categories ① to ⑩ by industry.
 - The "Kits" categories ㉓ and ㉔ are for works that use multiple sets of displays of different types. "Large Kits" are for gondola with a width of 900 mm or more, such as campaign kits, presentation kits for large stores, and mass display sales kits. "Small Kits" are for less than gondola with a width of 900mm.

ENTRY CATEGORY CLASSIFICATION and CODE TABLE

When making your online entry, please read pages 6 and 7 carefully and enter each appropriate code number for your entries.

TYPES & UNIT COSTS CATEGORIES		COUNTER TYPE			FLOOR TYPE		
		Code numbers by unit price: See page 6 - (1)					
INDUSTRY BASED	① Pharmaceuticals/Medical Supplies		Less than JPY3,000 11	JPY3,000 or more 12	13		
	② Toiletries	Less than JPY1,500 20	JPY1,500 to less than JPY3,000 21	JPY3,000 or more 22	23		
	③ Cosmetics counter type - Sales & Display A	Less than JPY1,500 31					
	④ Cosmetics counter type - Sales & Display B	JPY1,500 to less than JPY3,000 41					
	⑤ Cosmetics counter type - Sales & Display C	JPY3,000 or more 51					
	⑥ Cosmetics counter type - Announcement & Presentation A	Less than JPY5,000 61					
	⑦ Cosmetics counter type - Announcement & Presentation B	JPY5,000 or more 71					
	⑧ Cosmetics floor type A				Less than JPY5,000 81		
	⑨ Cosmetics floor type B				JPY5,000 to less than JPY10,000 91		
	⑩ Audio/AV Equipment/Communication /Office Equipment/Cameras		Less than JPY3,000 101	JPY3,000 or more 102	Less than JPY5,000 103	JPY5,000 or more 104	
	⑪ Stationery/Fashion Accessories/Glasses /Watches		Less than JPY3,000 111	JPY3,000 or more 112	Less than JPY5,000 113	JPY5,000 or more 114	
	⑫ Household Goods/Home Appliances counter type	121					
	⑬ Household Goods/Home Appliances floor type				131		
	⑭ Food/Beverages/Alcoholic Beverages		Less than JPY3,000 141	JPY3,000 or more 142	Less than JPY5,000 143	JPY5,000 or more 144	
	⑮ Transportation/Energy/Sports/Travel		Less than JPY3,000 151	JPY3,000 or more 152	Less than JPY5,000 153	JPY5,000 or more 154	
	⑯ Publishing/Entertainment/Finance/ Tobacco/ Other industries		Less than JPY3,000 161	JPY3,000 or more 162	Less than JPY5,000 163	JPY5,000 or more 164	
FORM BASED	⑰ Hangers A		Less than JPY1,000 171				
	⑱ Hangers B		JPY1,000 or more 181				
	⑲ Show Cards/Stickers		191				
	⑳ Shop Curtains/Banners/Flags/ Tapestries/Walls		201				
	㉑ Streamers/Standing Signboards/ Inflatable/Cutouts		211				
	㉒ Signs		Storefront and in-store signs 221				
	㉓ Small Kits		231				
	㉔ Large Kits		241				
OTHERS	㉕ POP packages		251				
	㉖ Sugowaza (Great Performance)		261				
	㉗ Global		271			Not eligible for Minister of Economy, Trade and Industry Award	
SPECIAL	㉘ Promotion/Space Design		281			Not eligible for Minister of Economy, Trade and Industry Award, Single run accepted	
	㉙ Minimum Lot		Counter 291		Floor 292	Not eligible for Minister of Economy, Trade and Industry Award. Eligible for POP ads from 1 to 9 units manufactured items.	

* Entries that are misclassified and have the wrong code number will be corrected during the first judging.

AWARDS

Silver Award

Awards will be presented to both advertisers and entry companies for outstanding works in each category.

Gold Award (Category Highest Award)

Awards will be presented to both advertisers and entry companies for the best work in each category.

* Gold Award winners will be entitled to purchase the Shop! OMA Trophy and enter the 2026 Shop! Global Awards. Information on purchasing the OMA Trophy and entering the Global Awards will be provided separately to all eligible winners.

Minister of Economy, Trade and Industry Award

Application is in preparation.

This award is the best of all Gold winners, and both advertiser and entry company will receive a certificate of commendation and the Shop! OMA Trophy.

Judge Special Award

This award will be presented to both the advertiser and entry company for the work that has been recommended by the third judges as a prominent work and evaluated as worthy of award.

Audience Award (newly established /temporary name)

We plan to establish a new award for the work that receives the highest number of votes by having each visitor vote on the spot. Details will be announced at a later date.

Award Ceremony

Details will be announced later.

RELEASE OF SELECTED AND WINNING WORKS

- All selected and winning works will be managed and released through JPM.
- Selected and winning works will be announced on the JPM website and the JPM In-Store Marketing Show & Awards website. The information for each work will be displayed as it was entered at the time of entry.
- When works are used for publications, public relations, education, etc. by JPM, all of them shall be delegated and approved for JPM. In addition, works with Gold Award or higher may be posted on the JPM website with the approval of advertisers and entry companies.
- Selected and winning works will be exhibited at the JPM In-Store Marketing Show & Awards.
- Selected and winning works will be published in the guidebook with reference to the information provided at the time of entry.

Important Notes

- Entry fees will not be refunded unless the Government of Japan or the Tokyo Metropolitan Government orders the event to be cancelled. The judging fees will not be refunded even when the event was cancelled.
- When displaying the actual products with the exhibits, it is the responsibility of each exhibit company to manage them.
- The exhibit companies are responsible for the copyright and industrial property rights of the exhibits.
- If you have any questions, please contact JPM (Email: jpm_show@jpm-inc.jp).

All information in these entry guidelines is current as of July 2025.



Japan Promotional Marketing Institute, Inc.
1-16-8 Shintomi, Chuo-ku, Tokyo 104-0041 Japan <https://www.jpm-inc.jp>
Email: gohara@jpm-inc.jp